

Cosmic Ray Spectrum Measured by the PRISMA-32 Setup

K. O. Yurin^a, F. A. Bogdanov^a, D. M. Gromushkin^a,
Yu. V. Sten'kin^{a,b}, and O. B. Shchegolev^b

^a National Research Nuclear University “MEPhI”,
Kashirskoe sh. 31, Moscow, 115409 Russia; e-mail: KOYurin@mephi.ru

^b Institute for Nuclear Research, Russian Academy of Sciences,
pr. 60-letiya Otyabrya 7a, Moscow, 117312 Russia

Received September 20, 2017

Abstract—The results of measurements of the spectrum of extensive air showers (EASs) by the number of neutrons detected by the PRISMA-32 setup are presented. The neutron component is formed during the interaction of high-energy shower hadrons with nuclei of atmospheric and Earth's surface atoms. The PRISMA-32 setup consists of 32 en-detectors and operates in the continuous mode for about 5 years.

DOI: 10.3103/S1068335617100050

Keywords: extensive air shower, neutron component, thermal neutrons.

The EAS neutron component is almost unstudied, since, until recently, there were no large and inexpensive neutron detectors applicable to develop large systems on their basis. At the same time, exactly the study of the EAS hadron component, being the main EAS component and determining all its basic properties at the observation level, can give additional information on the nature of the observed knee in the cosmic ray spectrum.

The project of the development of the setup for studying the EAS neutron component resulting from the interaction of high-energy shower hadrons with medium nuclei was proposed about 15 years ago [1]. In 2012, based on the Unique Scientific Facility NEVOD (MEPhI) in collaboration with the Institute for Nuclear Research, Russian Academy of Sciences, the PRISMA-32 setup [2] of 32 en-detectors was developed. This setup can simultaneously detect two main EAS components, i.e., the electron (e) and neutron (n) ones.

The first data on the temporal and spatial distribution of EAS neutrons were obtained on the PRISMA-32 setup. The temporal distribution of EAS neutrons is described by the double exponential function with the parameters $t_1 = 0.49 \pm 0.01$ ms and $t_2 = 3.44 \pm 0.2$ ms. The first exponent is related to the average lifetime of the neutrons coming from under the detector, i.e., the locally produced ones; the second exponent is related to the neutrons produced in the interaction of the hadron component with the building roof or walls [3]. The relation between the energy release of the EAS charged component and the number of detected neutrons (the number of recorded neutrons reaches one hundred for 32 detectors while detecting $\sim 10^6$ charged particles [4]) was obtained. The spatial distribution function (SDF) of neutrons was measured, which, as the temporal distribution, can be described by the double exponential function with the exponent parameters $r_1 = 1$ m and $r_2 = 10.5$ m [5].

The PRISMA-32 setup is arranged within an experimental building at the fourth floor level and consists of two independently operating clusters of 16 en-detectors each (Fig. 1). The nonuniform arrangement of detectors is caused by free space in the experimental system in which other setups operate, including the Cherenkov water detector (at the center) [6]. The distance between detectors is 2.5 m (along the X axis) and 5 m (Y axis). The total setup area is ~ 500 m². The charged particle and neutron measurement ranges are from 20 to 75000 particles per detector and from 1 to 1000 neutrons per detector.

EAS neutrons are detected using a detector with a thin inorganic scintillator ZnS(Ag) and LiF, where Li is enriched with ⁶Li isotope to 90%. The schematic diagram of the detector is shown in Fig. 2. The area of each en-detector is 0.36 m². Information is picked up from two photomultiplier dynodes: the 12th

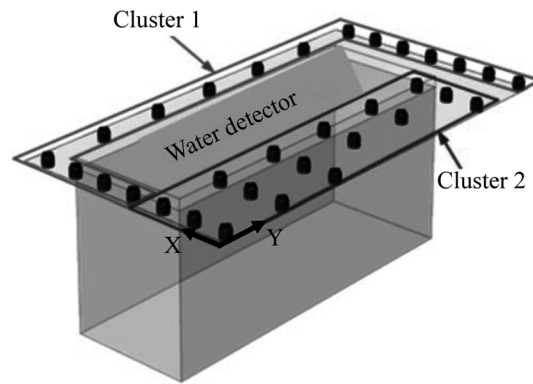

Fig. 1. Schematic diagram of the PRISMA setup.

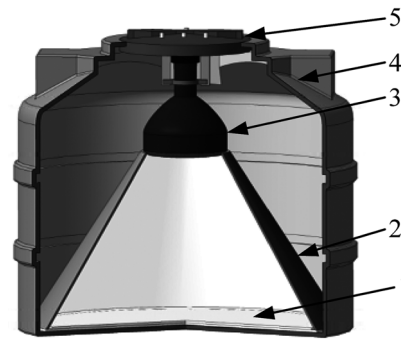

Fig. 2. Schematic diagram of the en-detector: (1) scintillator, (2) light-collecting cone, (3) FEU-200 photomultiplier, (4) light-tight box, and (5) housing cover.

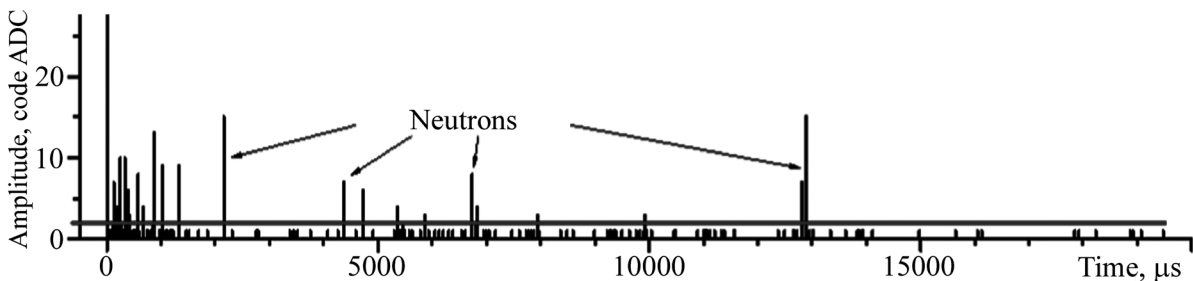

Fig. 3. Oscillogram of the detected EAS event.

dynode is used to measure the EAS electron–photon and neutron components, and the 7th dynode is used to increase the dynamic range for the charged component. All pulses are integrated in a preamplifier with a time constant of $1 \mu\text{s}$.

The data storage trigger is the EAS front detection, the coincidence of two and more detectors in the cluster, the signal level in which exceeded 4 mV (20 charged particles). The detector signals are digitized using fast ADCs operating at a frequency of 1 MHz (in the case of EAS measurements, a 20000-point oscillogram is stored). The example of the EAS measurement oscillogram (for one detector) is shown in Fig. 3.

In the first $100 \mu\text{s}$, the energy release of passed charged particles (the shower front) is determined; from $100 \mu\text{s}$ to $20000 \mu\text{s}$, delayed neutrons are detected. The neutron is understood as a signal exceeding 8 mV . The signal from charged particles, neutron, natural background, and photomultiplier noise can satisfy the conditions for detecting EAS neutrons, but their number does not exceed one count per 20 events. An on-line program analyzes oscillograms and determines the energy release of passed charged

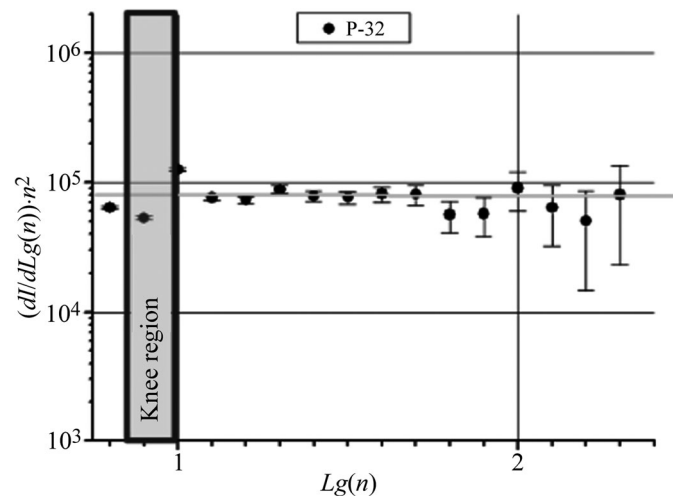

Fig. 4. EAS neutron number spectrum measured by the PRISMA-32 setup.

particles, the number of detected neutrons, and the time of their detection after the EAS front with a step of $100 \mu\text{s}$ in each detector.

Information for 5 years of the PRISMA-32 setup operation was used in data processing. The setup operation time is $\sim 95\%$ of the calendar time.

As a result of the data processing, the EAS neutron number spectrum was obtained, i.e., the dependence of the number of selected events I on the number n of neutrons in them, which obeys the power law with the slope $\beta = 2.0$ (Fig. 4; for clarity, the Y axis is multiplied by n^2). Since the number of EAS neutrons is proportional to the number of hadrons [7], the above result can be compared to the data on the EAS hadron number spectra. In 2001, the experimental EAS hadron number spectrum measured by the KASCADE calorimeter was published [8]. The hadron spectrum slope measured in [8] was from 1.9 to 2.0, depending on the EAS energy.

Conclusions. The EAS spectrum on the number of detected neutrons in the PeV energy region of primary particles detected by the PRISMA-32 setup was obtained. The spectrum exhibits the power-law behavior with an integral exponent of -2.0 . This value is in good agreement with the published experimental data for EAS hadrons.

ACKNOWLEDGMENTS

This study was performed within the framework of the Grant of the President of the Russian Federation for the state support of young Russian scientists-candidates of sciences (MK-7597.2016.2) on the Unique Scientific Facility “NEVOD Experimental System”. The study was also supported by the Russian Foundation for Basic Research (projects nos. 16-32-00054 and 16-29-13067).

REFERENCES

1. Yu. V. Stenkin and J. F. Valdes-Galicia, in *Proceedings of the 27 International Cosmic Ray Conference, Hamburg, Germany, 2001* (Copernicus Gesellschaft, Katlenburg-Lindau, 2001), Vol. 4, p. 1453.
2. D. M. Gromushkin et al., *J. Instrum.* **9**, C08028 (2014).
3. D. M. Gromushkin et al., *Izv. Ross. Akad. Nauk Ser. Fiz.* **79**, 414 (2015) [*Bull. Russ. Acad. Sci. Phys.* **79**, 380 (2015)].
4. D. M. Gromushkin et al., *J. Phys.: Conf. Ser.* **409**, 012044 (2013).
5. O. B. Shchegolev et al., *J. Phys.: Conf. Ser.* **718**, 052038 (2016).
6. A. A. Petrukhin, *Usp. Fiz. Nauk* **185**, 521 (2015) [*Phys. Usp.* **58**, 486 (2015)].
7. D. M. Gromushkin et al., *Izv. Ross. Akad. Nauk Ser. Fiz.* **77**, 704 (2013) [*Bull. Russ. Acad. Sci. Phys.* **77**, 701 (2013)].
8. J. R. Hörandel et al., in *Proceedings of the 27th International Cosmic Ray Conference, Hamburg, Germany, 2001* (Copernicus Gesellschaft, Katlenburg-Lindau, 2001), Vol. 1, p. 137.

Presented at the 6th International Youth Scientific School-Conference “Current Problems of Physics and Technologies”.